

PIONEER

WORLD-FAMOUS BRAND IN HI-FI REPRODUCTION

**PROFESSIONAL,
BELT DRIVE
STEREO TURNTABLE**

PL-41
PU-41B

Thank you for your purchase of Pioneer's Model PL-41. You will get many years of pleasure from this qualitycrafted component. For the highest performance of the PL-41, read this manual carefully and follow the directions indicated.

OPERATING INSTRUCTIONS



LUBRICATION

Mechanical noises, and wow and flutter usually result from insufficient lubrication in rotating parts. In some instances, lack of lubricant may cause the motor to freeze or to burn its windings. Be sure that you lubricate the specified points at least once every two months if the PL-41 is used for home entertainment, and two to three times a month if used for professional purposes.

One lubricating point is shown in Fig. 21 (lubricating hole.). Another lubricating point is the center shaft of the turntable platter. Remove the platter and lubricate the shaft with two or three drops of oil at the same time you lubricate the lubricating hole. In this case, make sure not to let oil adhere to the belt or capstan. If oil gets on the belt or capstan, remove it with a cloth dampened with alcohol.

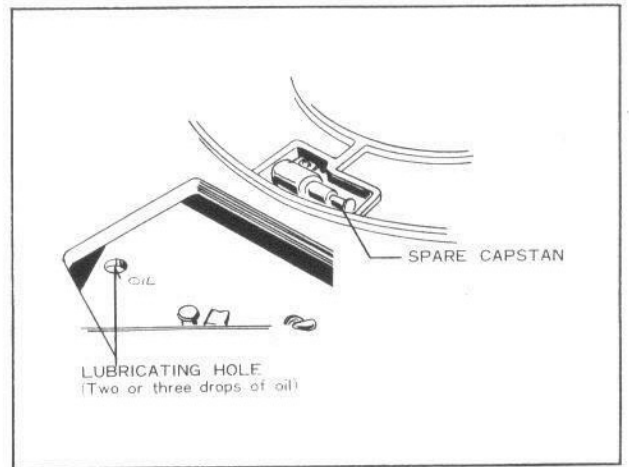

Fig. 21

TROUBLE-SHOOTING

1. TURNTABLE SPEED IS IRREGULAR

In most cases, irregular turntable speed results from lack of lubricating oil in the bearing of the turntable shaft. If irregular speed is noticed, remove the bottom cover, unscrew the bearing cap on the bottom end of the platter shaft, pull out the shaft, wipe off the used oil with a soft cloth, put the shaft and cover back, and apply several drops of oil to the shaft from the platter side. For lubrication, use the furnished oil or its equivalent.

2. WOW AND FLUTTER

Wow and flutter usually result from oil on the capstan or belt. Check the surfaces of the capstan and belt, and if oil is found wipe it clean with a soft cloth dampened with alcohol.

CAUTION

Never use other solvents.



SPECIFICATIONS

Turntable drive	2-speed, belt-drive system
Motor	4-pole, hysteresis synchronous type
Turntable Platter	31 cm, 12 1/4" in diameter, aluminum alloy diecast, 4 lb 14 oz, 2.2 kg
Wow and Flutter	Less than 0.08%
S N ratio	More than 50 dB
Tonearm	Static balance type
Cartridge	PL-C9 (moving magnet type)
Stylus	PL-N9 (0.65 mils radius diamond)
Frequency Response	15 – 21,000 Hz
Channel Separation	More than 30dB/1,000 Hz
Output Voltage	5 mv 1.000 Hz 50 mm/sec
Load Resistance	50 K Ω
Compliance	12 x 10 ⁻⁶ cm/dyne
Stylus Pressure	2 – 3 g
Power Requirement	110, 117, 130, 220 or 240V 50 or 60 Hz
Power Consumption	25 VA (21 W)
Dimensions PL-41	20" (W) x 16" (D) x 7 1/2" (H) 508 (W) x 406 (D) x 191 (H) mm
PU-41B	16 6/8" (W) x 12" (D) x 6 3/4" (H) 425 (W) x 305 (D) x 172 (H) mm
Weight Without package	23 lb, 10.5 kg
With Package	34 lb, 15 kg

NOTE:

Specifications and the design may be subject to modification without notice.

Although the instructions in this manual are related to the PL-41, they are also applicable to Model PU-41B which is PL-41 less the wooden base and the plastic hood.

PIONEER

PIONEER ELECTRONIC CORPORATION

15-5, 4-Chome, Ohmori-nishi, Ohta-ku, Tokyo, Japan

PRINTED IN JAPAN

PIONEER ELECTRONICS U.S.A. CORPORATION

140 Smith St., Farmingdale, L.I., N.Y. 11735, U.S.A.

PIONEER ELECTRONIC (EUROPE) AG.

59, Forch Strasse, 8032 Zurich, Switzerland

<R12-734-0>

<70A05F03S>

ASSEMBLY

NOTE: The turntable platter will be found under a cardboard sheet in the lower portion of the packing case.

1. REMOVE THREE BASE PLATE CLAMPING SCREWS.

The clamping screws are tipped with red paint. When they are removed, the base plate is freed from the base plate and supported by three suspension springs with plastic cushions. (Fig. 1)

2. LINE VOLTAGE AND LINE FREQUENCY

A. LINE VOLTAGE SELECTOR SWITCH

Check the line voltage in your area before mounting the turntable platter on the unit.

Note. That Model PL-41 has been set to 220 to 240V line voltage operation when delivered. If the line voltage in your area is somewhere from 110V to 130V, set the line voltage selector switch to 110 to 130V. (Fig. 2)

B. CAPSTAN EXCHANGE

Two kinds of capstans are furnished with the Model PL-41, one for 50 Hz operation and the other for 60 Hz operation. The 50 Hz capstan has a larger diameter, and the 60 Hz capstan, a smaller diameter with a groove in the lower part. The Model PL-41 is usually set for operation of the line frequency in the area to which it is shipped; however, if you move to some other area where the line frequency is different, you must change the capstan for proper turntable speeds. Find out the line frequency in your area and set the proper capstan in your turntable as follows:

- You will find a capstan set up on the motor shaft and a spare capstan laid on the base plate.
- Loosen two setscrews on the side of the capstan using the small screwdriver furnished in the accessory group, and remove them. Then, pull out the capstan from the motor shaft. (Fig. 3)
- Loosen the clamp that is holding the spare capstan, remove the capstan from the resting place, and install it on the motor shaft. (Fig. 3)
- Before tightening the setscrews, set the capstan in position on the motor shaft so that the center of the belt is aligned with that of the belt guide. (Fig. 4)
- Set the line frequency switch to the proper frequency position. (Fig. 3)

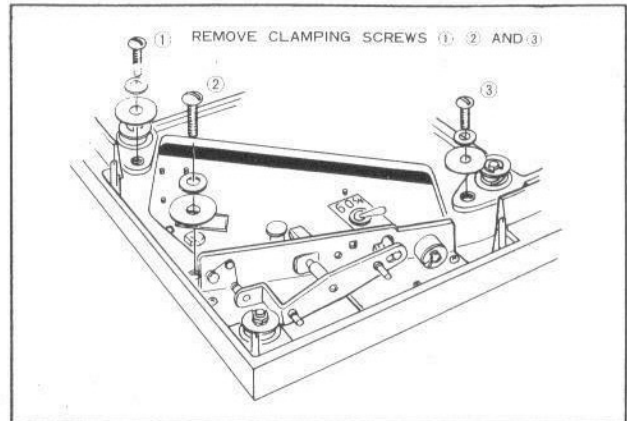

Fig. 1

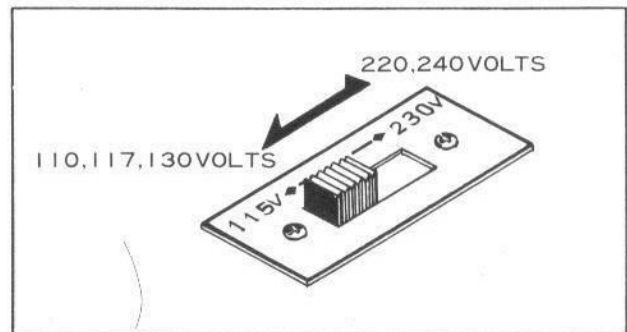

Fig. 2

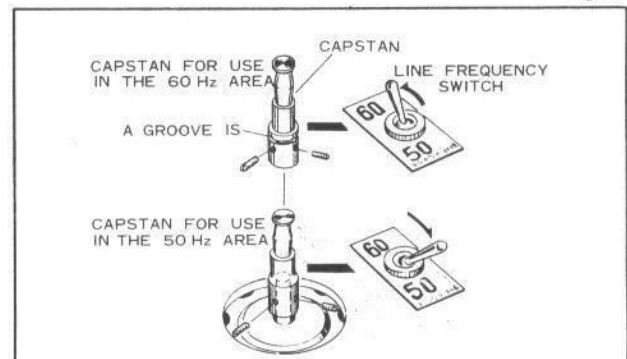

Fig. 3

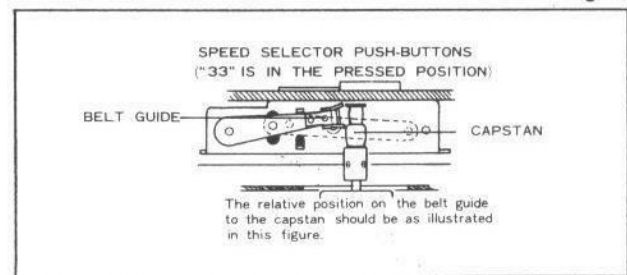

Fig. 4



3. MOUNT THE TURNTABLE PLATTER

Unpack the turntable platter and place it on the center shaft.
Place the two rubber mats on the platter.

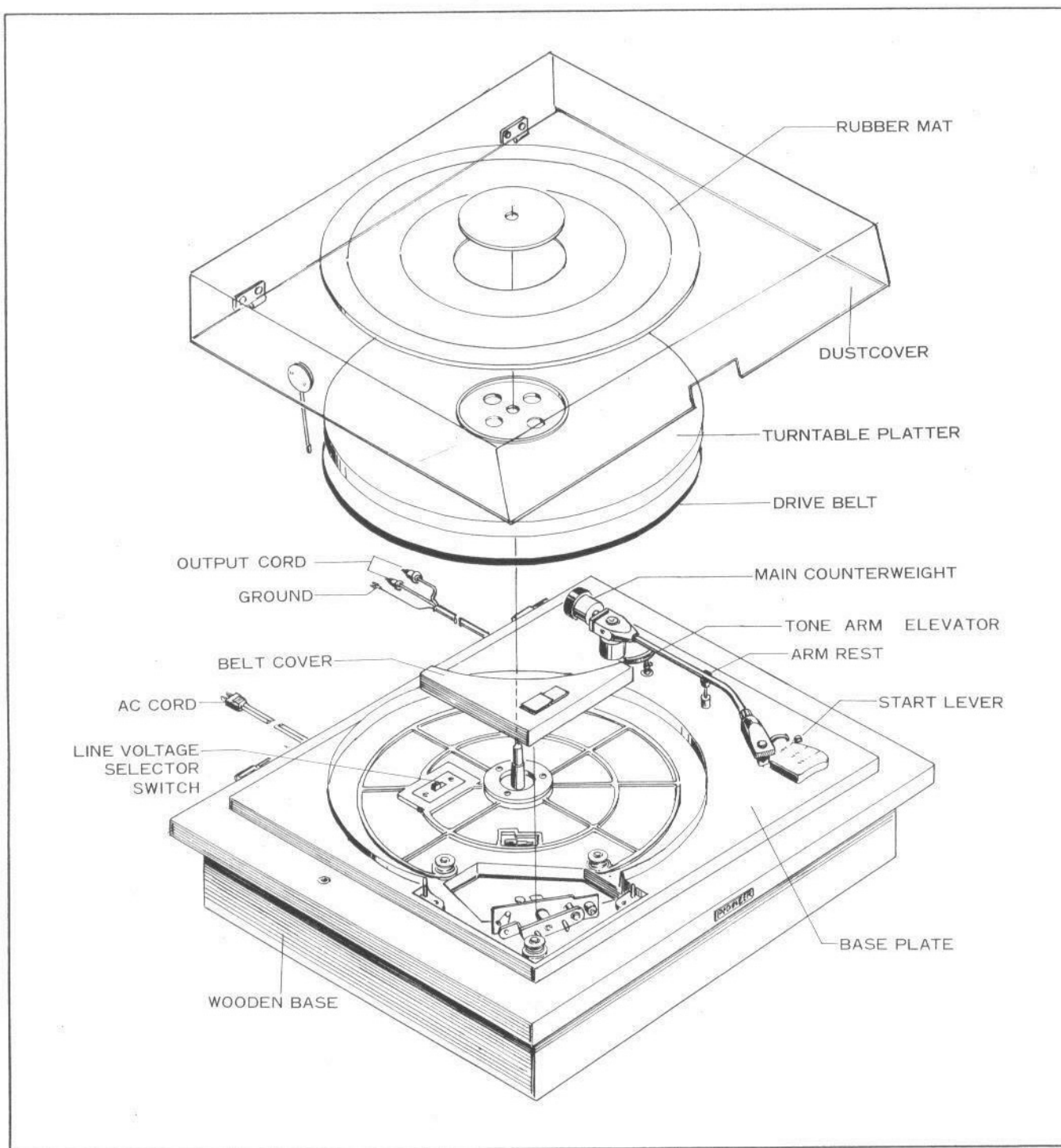

Fig. 5

4. SET THE BELT ON THE CAPSTAN

A short piece of ribbon is inserted under the belt for convenience in pulling the belt. Take out the belt cover (See fig. 6) from the packing case and temporarily mount it over the belt drive mechanism area to see if the speed selector lever is in the "33" (33-1/3 rpm) position. If not, press the "33" pushbutton. Remove the belt cover and put it aside for later use. Now, pulling the ribbon, set the belt around the smaller-diameter portion (for 33-1/3 rpm speed) of the capstan. After the belt is in its proper position, remove the ribbon.

5. MOUNTING OF TONEARM

A. MOUNT TONEARM ON BASE PLATE

Unpack the tonearm assembly carefully, and insert the tonearm supporting shaft in the tonearm stand on the motor board as illustrated in the figure. Hold the tonearm supporting shaft in the stand in such a manner that the two red dot marks each provided on both tonearm support and stand are aligned with each other, and then secure the tonearm support to the stand using the furnished screwdriver. (Fig. 8)

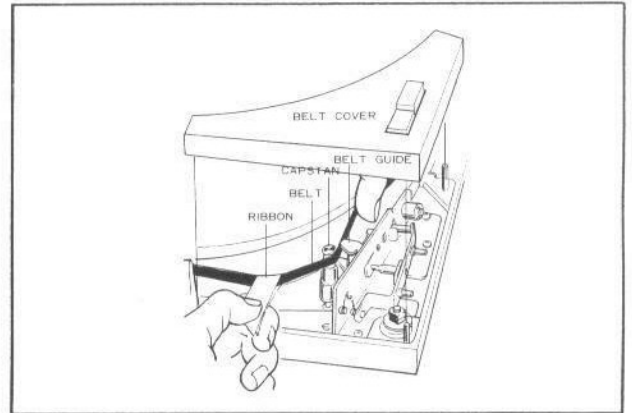

Fig. 6

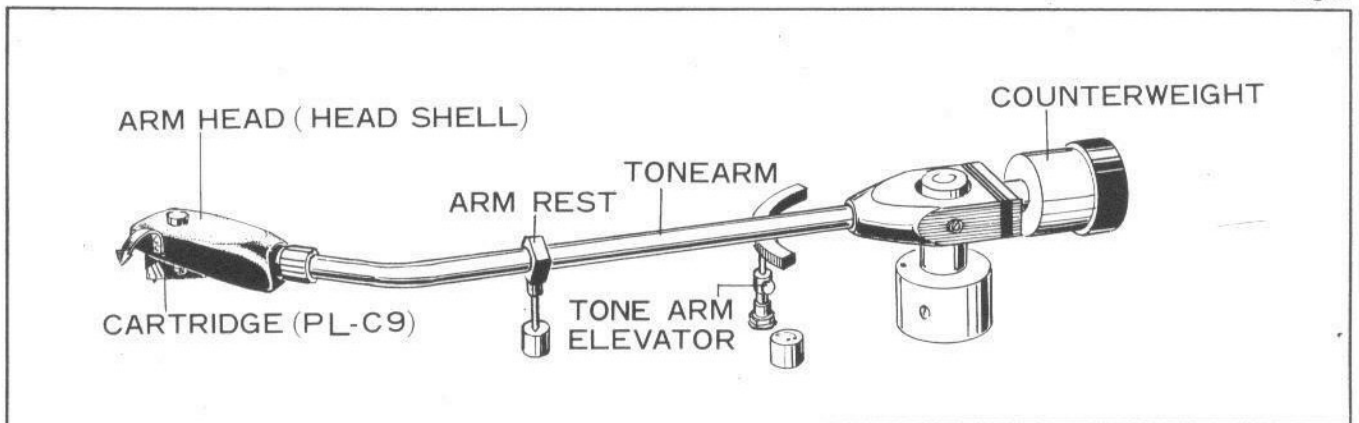

Fig. 7

B. CONNECT OUTPUT CORD OF TONEARM STAND

Remove the rear cover from the cabinet, and the AC power cord and the output cord will be found. Put the output cord plug in the connecting socket on the rear of the tonearm support. (Fig. 8)

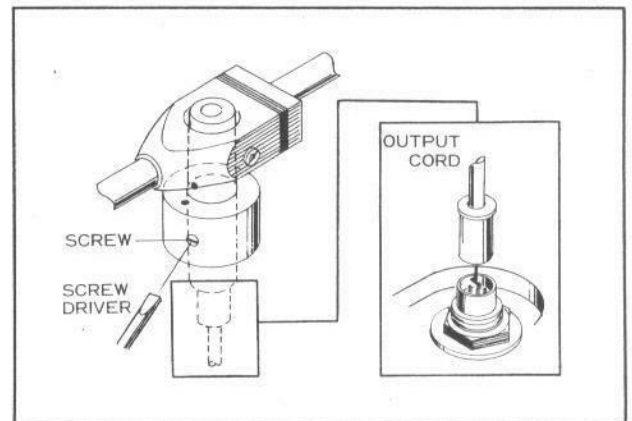

Fig. 8



C. FIT MAIN COUNTERWEIGHT ONTO TONEARM

Fit the main counterweight on the rear of the tonearm, and slightly turn the threaded knob which is provided on the back side of the tonearm. Secure the knob to such an extent that the front portion of the counterweight will not rotate when turning the rear portion of counterweight (stylus pressure control dial) marked with pressure readings around its surface. (Fig. 9)

D. ATTACH THE ARM HEAD

Insert the arm head neck into the end of the arm pipe and tighten the locking collar. With the Model PL-41, you can adjust the verticality of the stylus over a range of ± 2 to 3° . Holding the arm pipe tightly with one hand, turn the arm head with the other hand until the stylus becomes perfectly perpendicular to the record surface. (Fig. 10)

STYLUS PRESSURE ADJUSTMENT

Remove the stylus cover from the cartridge. Turn the counterweight either to the right or to the left by hand to bring the red dot mark on the counterweight to the uppermost position. Turn only the dialed portion of the counterweight, holding the front portion, and set the 0-reading of the dial to the red dot now placed on the uppermost position. With the tonearm off the arm rest, balance the tonearm by inching the counterweight back and forth. When the tonearm is balanced, turn only the dialed portion of the counterweight and set a specified pressure reading to the red dot mark. (A recommended stylus pressure is 2 to 3.) The reading opposite to the red mark denotes the stylus pressure to be applied. (Fig. 11) (Fig. 12)

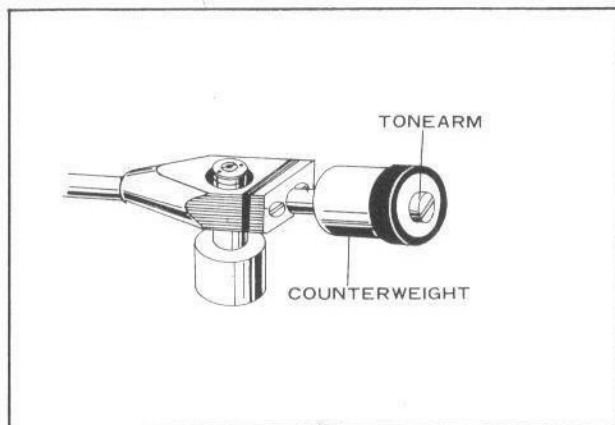

Fig. 9

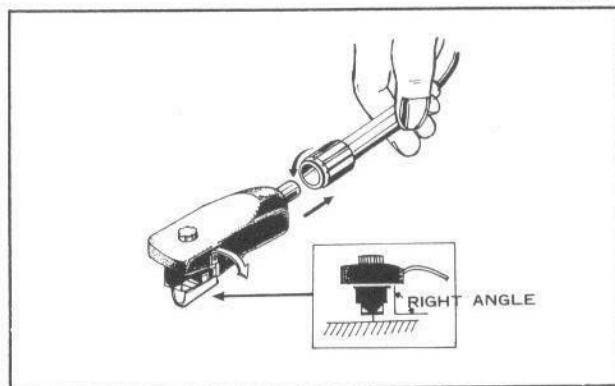

Fig. 10

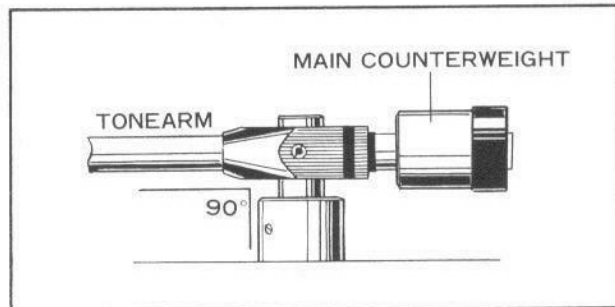

Fig. 11

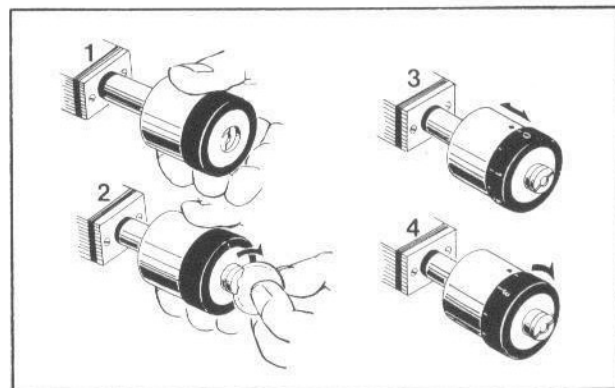

Fig. 12

FUNCTIONS OF CONTROLS

1. SPEED SELECTOR PUSH-BUTTONS

The PL-41 is a two-speed model: 33-1/3 rpm and 45 rpm. Two push-buttons provided on the belt cover control selection of speeds. Pressing the desired speed push-button will automatically set the turntable for operation of the speed marked on the push-button. The PL-41 is a belt drive system in which the motor drives the turntable platter through a belt. Therefore, changing turntable speeds must be done only when the turntable platter is rotating. (Fig. 13)

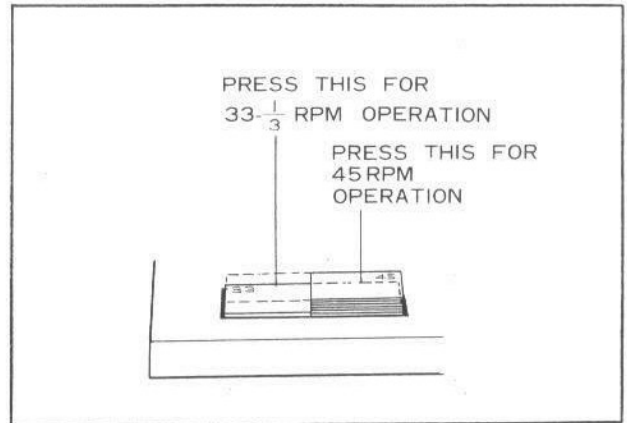

Fig. 13

2. START LEVER

The start lever has three control positions; "OFF", "ON", and "DOWN". The lever is used to turn the motor on and off and to raise or lower the tonearm. The turntable operation for each lever position is as follows: (Fig. 14)

ON Bringing the lever from "OFF" to "ON" will raise the tonearm and apply power to the motor, causing the turntable to start rotating. If the lever is brought from "DOWN" to "ON" while the record is being played, the arm head will quietly float up from the record surface. This eliminates the danger of dropping the arm head on the record.

DOWN After the tonearm is raised, the arm head should be brought above the cueing position. Then, bringing the lever to "DOWN" will cause the head to float down quietly with the stylus point landing in the cueing groove.

OFF Bringing the lever from "ON" to "OFF" will remove power from the motor. If the lever is brought from "DOWN" to "OFF" directly, the tonearm will float up and stay there while the motor is shut off. Be sure that the lever is brought to "OFF" after using the PL-41.

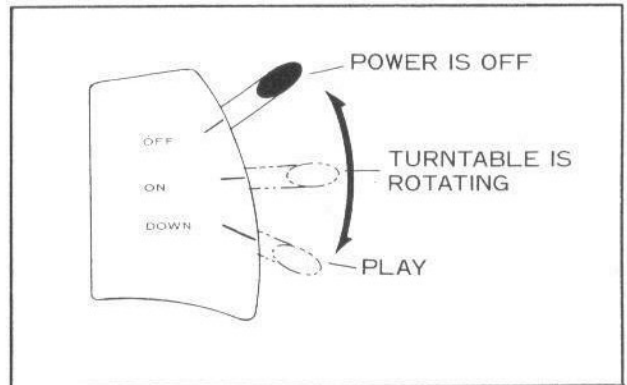

Fig. 14

3. TONEARM ELEVATOR

As mentioned in the preceding paragraph, the tonearm is raised or lowered with the start lever. This operation is accomplished by the tonearm elevator shown in Fig. 15. The travelling stroke of the tonearm can be adjusted by loosening the lock nut.

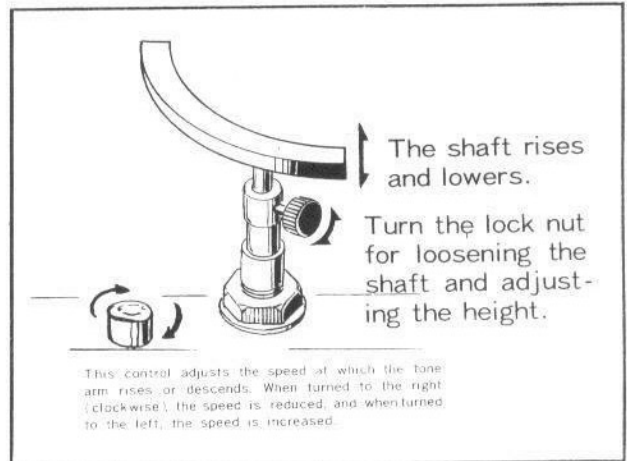

Fig. 15

4. ARM REST AND 45-RPM ADAPTER

The arm rest supports the tonearm in place when the tonearm is not in use. A clamp is provided on the arm rest. It is good practice to keep the tonearm in the clamp except when the Model PL-41 is in use.

A 45-rpm adapter is supplied in the accessory group, which permits 45-rpm records to be placed on the PL-41.



CONNECTION TO A STEREO AMPLIFIER

- The furnished cartridge, PL-C9, is a moving magnet type cartridge. Therefore, use the MAG input jacks of your amplifier for connection to the cartridge.
- The output cord of the PL-41 has three leads at its end; the first (white) is marked with "L", the second (red), "R", and the third (black) with no letter.
- The "L" lead has a pin plug for connection to the left channel input jack on your amplifier, and the "R" lead, a similar pin plug for connection to the right channel input jack. The black lead has a terminal lug for connection to the grounding terminal on your amplifier. (Fig. 16)

OPERATION

The Model PL-41 is designed specifically for ease of operation. Follow the steps described below:

- (1) Place the record on the turntable platter.
- (2) If the stylus cover is still on the cartridge, remove it.
- (3) Set the start lever to "ON"; the turntable will begin rotating.
- (4) Press the desired speed push-button.
- (5) Move the tonearm by hand and bring the arm head above the cuing position.
- (6) Move the start lever from "ON" to "DOWN". The tonearm will quietly float down until the stylus gently fits in the cuing groove. The music starts.
- (7) When the record is over, set the lever to "OFF" and bring the tonearm back onto the arm rest. If the turntable is not used for a while, clamp the tonearm to the arm rest.
- (8) Another way to operate the turntable.

When you play an LP record, you may desire to listen to only specific portions of the record. In this case, you can set the tonearm position by hand without turning the motor off by maneuvering the start lever only between "DOWN" and "ON".

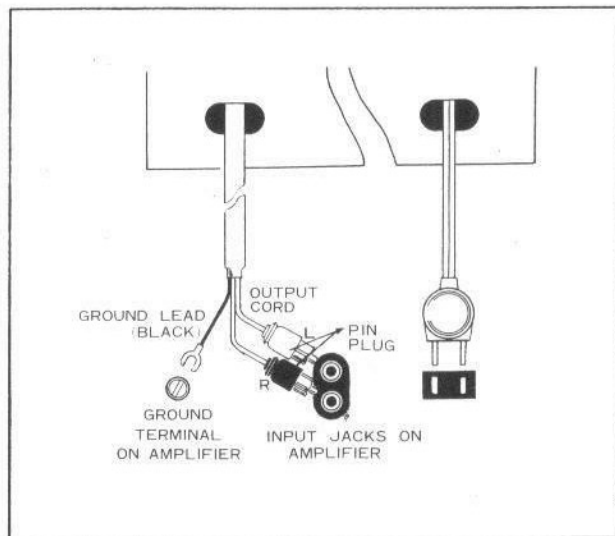

Fig. 16



3. BE CAREFUL OF SHOCK OR VIBRATION

The Model PL-41 operates with a very small tracking force. Select the location of the PL-41 with care. It should be in a stable position. It is a good practice to keep the unit away from the loudspeaker cabinets as far as possible.

4. ALWAYS KEEP THE STYLUS CLEAN

Dust collected on the stylus point degrades the quality of reproduced sound. If dust is found on the record surface, remove it with a soft, clean cloth dampened with a commercially available record cleaner. When cleaning the stylus, care must be exercised not to touch the stylus with the fingers. Use a soft brush, drawing it gently along the stylus in the direction of the tonearm's axis.

5. HUM

Hum is a low-pitched droning noise, often 60 or 50 Hz, resulting from a loose connection of the ground lead. If hum occurs:

- Check the connection of the PL-41 ground lead (the black lead with a terminal lug) to your amplifier. If loose or not connected at all, correct the connection.
- Check to see if the output cord of the PL-41 is running near the power transformer of your amplifier. Changing the relation of the PL-41 and the amplifier will often eliminate hum.

6. BUZZ

"Buzz" is a relatively high-pitched noise resulting from induction due to exposure to high intensity TV signals. In this case the pickup cord is functioning as an antenna for picking up the TV signals. If buzz occurs, either make the tonearm cord shorter or change the positional relation between the turntable and the amplifier.

7. HOWLING

Howling is acoustical feedback from loudspeakers to the tonearm or cartridge. Increasing the distance between the loudspeakers and the turntable, or even better, laying a soft cushion underneath the turntable base will eliminate howling.

REPLACEMENT

1. STYLUS REPLACEMENT

The furnished cartridge, PL-C9, uses a diamond stylus, PL-N9. This stylus should last for about 200 to 500 hours of operation. For record protection, it is recommended to replace it before it wears out completely. Replace the stylus as follows: disconnect the arm head from the tonearm pipe. The stylus is held in position in a plastic holder. Pull out the plastic holder with the stylus, diagonally. Replace the stylus with a new one and put the holder back into the cartridge. When purchasing a replacement stylus, specify PL-N9. (Fig. 17)

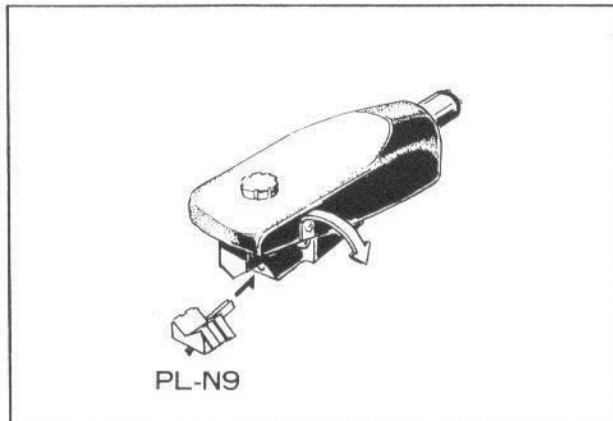

Fig. 17

2. USING A DIFFERENT CARTRIDGE

The mount for the arm head coupling connector conforms to international standards. When using a pick-up cartridge of any other type, the leads of the arm head must be connected to the pins of the cartridge as follows: (Fig. 18) (Fig. 19)

White	left channel (+)
Blue	left channel (-)
Red	right channel (+)
Green	right channel (-)

Adjust the cartridge position so that the distance (overhang) between the stylus and the center of the turntable platter shaft becomes $9/16''$ as shown in Fig. 20.

If the new cartridge is lighter than the original cartridge (type PL-C9), it is necessary to balance the tonearm once again.

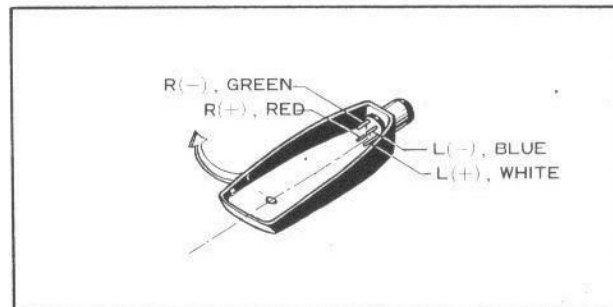

Fig. 18

OPERATING CONSIDERATIONS

1. CHANGE TURNTABLE SPEED ONLY WHEN THE TURNTABLE IS ROTATING

In the belt drive system, the turntable speed is changed by shifting the belt up or down on the step capstan by a lever that is controlled with the speed selector push-buttons. For this reason, when the speed is to be changed, the turntable must be rotating to facilitate shifting of the belt. An attempt to change the speed forcibly by pressing a push-button while the turntable is stationary may damage the belt. (In other words, the start lever must always be in the "ON" position whenever the speed is changed.)

2. DO NOT HOLD THE ROTATING TURNTABLE BY HAND.

Holding the rotating turntable by hand may cause the belt to go out of the track.

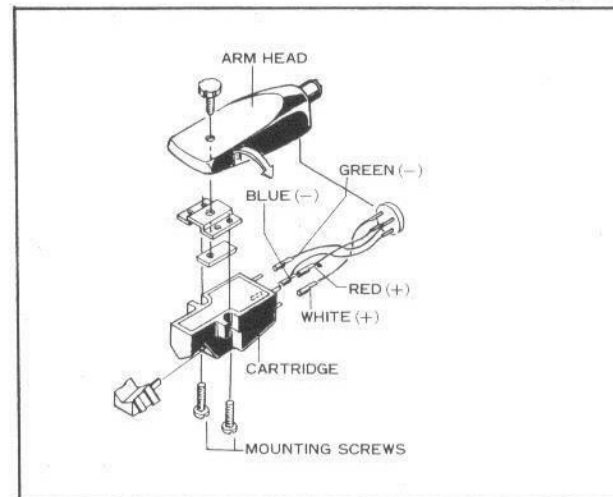

Fig. 19

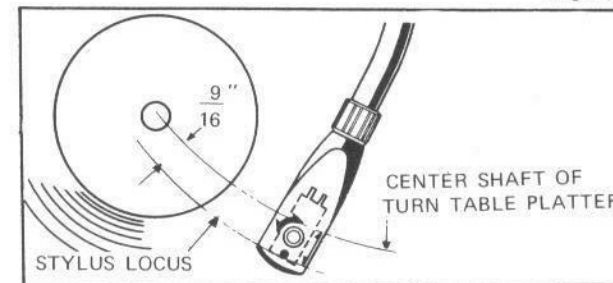

Fig. 20